

Instructions on How to Mitre

Although a mitred moulding appears to be a simple joint to make, we have been regularly asked by our customers how to do a mitre. We have, therefore, included this worksheet in our catalogue in the hope that it will prove to be helpful to those of you who 'have mitred and failed!'

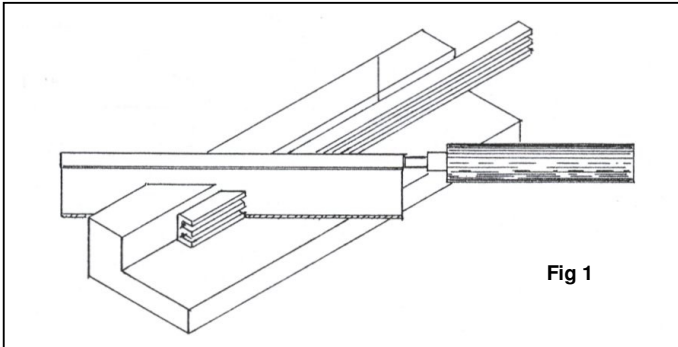

Ref: MBD – Mitre Board

Fig 1 shows a piece of moulding being cut on the mitre board. After this cut, the length of the moulding required is marked on the outside edge of the moulding and then cut as in Fig 2.

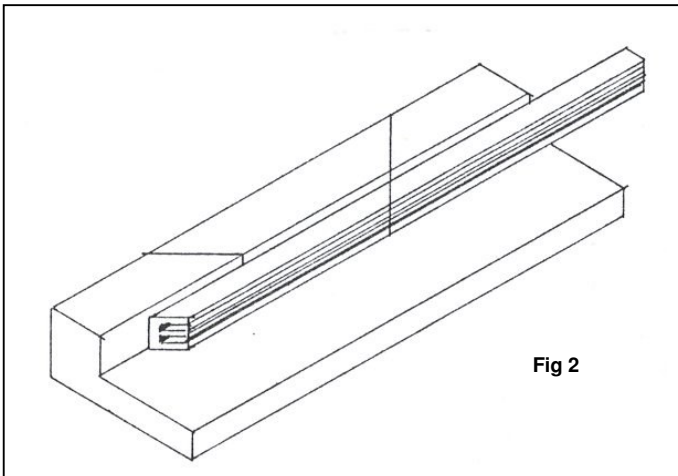

Having cut the first piece of moulding to size it is necessary to repeat this at least once when making a picture frame and more often if you have more than one frame of the same size. Repeating the same length of mitre moulding seems to cause problems. In Fig 3 we show a simple but effective method whereby the moulding of the same length can be repeated as often as necessary.

The procedure is as follows:

Cut the first mitre then cut to the required length as in Fig 2. Leave the saw blade in position in your mitre board and the piece of moulding (already cut) tight up to the saw blade, position the stop as in Fig 3. Remove the moulding which has been cut to length and repeat the process. i.e. first cut as Fig 1 and then move the moulding up to the 'stop' and do the second cut. This should then be the same length as the first piece of moulding. This operation can be repeated as often as necessary to give the number of mitred mouldings required.

One point to note when using your saw is to allow it to cut easily without forcing it.

You should now have mastered the mitre!

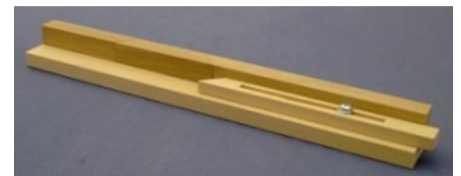
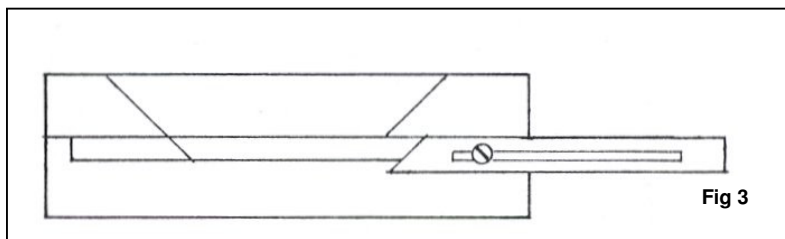

Ref: AMBD – Adjustable Mitre Board